

# **High-speed Check weigher**

## **Instruction Manual**

# CONTENTS

1. Security instructions.....	-3-4-
2.Package,transportation and storage.....	-5-
3. The introduction and specification of check weigher.....	-6-
3.1The introduction of the check weigher.....	-6-7-
3.2 The main technical parameters of the check weigher.....	-8-
4. The external structure of machine.....	-9-
5. Operating instructions.....	-10-
5.1Start up the main screen.....	10-11-
5.2 Statistical reports.....	-12-
5.3 Main interface parameter Settings.....	-13-14-
5.4 Calibration interface.....	-15-
5.5 Parameter Settings interface.....	-16-
5.6 Change the password.....	-17-18-
6. Maintenance.....	-17-18-
7. Repair.....	-18-19-

## Chapter 1: Security Instructions

### 1. Read and grasp the importance of the instruction manual:

Please read the instruction manual carefully before use, in order to avoid machinery damage or cause unnecessary personal injury.

### 2. Mechanical hazard and prevention:

It must stick the warning stickers in the mechanical transmission parts which may injure the human body. Warning when the machine is running, the human body can not touch these parts.

### 3. Electrical hazard and prevention:

The machine has equipped with the leakage protection switch, stop switch, the power ground to prevent any danger from electrical components.

### 4. Electromagnetic and other radiation hazard and prevention:

To prevent the dangerous of electromagnetic and radiation, this machine adopts the excellent shielding materials to shield the danger and interference from all kinds of electromagnetic.

### 5. Noise hazards and prevention:

This machine adopts the subwoofer motor and the bearings of high speed, low noise as the transmission parts to reduce the danger of noise and interference.

### 6. The measures of prevent fires:

To prevent fires, the machine when choosing the raw materials which are required to comply with the relevant fire rating, including all kinds of electrical and electronic components, electrical connectors, all kinds of transmission parts and plastic parts.

### 7. The individual protection requirements for the worker when using the machine:

The machine operator can not open the power box without permission, when the machine is running, all the body parts especially the hands can not be closed and touched the transmission parts of the machine.

### 8. Safety warning labels instructions for Machine:



a) High risk warning marks: with the marked place which means have high pressure, don't touch here to avoid personal injury.



b) Safety warning sign: this symbol indicates that dangerous! Warning! Attention! It's reminding people vigilant with the signs of place, it may hurt the human body

## High-speed Check weigher

---

or cause damage to the machine, please don't touch the parts with these marks at will when it running.

### **9. Work environment**

- 1) Installation location: Horizontal, no vibration.
- 2) Grounding: Grounded safely.
- 3) Interference sources: shield and stay away from it.

**10. Prohibit to impacting or weighing heavily of the intermediate weighing conveyor.**

**11. When maintain and clean the machine must turn off the power.**

**12. When the electrical parts malfunction, the non-electronic engineers for maintenance are prohibited.**

# High-speed Check weigher

---

## Chapter 2: Package, transportation and storage

### 1、 The package of the machine

a) Package conditions of machine:

Due to the machine has a certain weight, when packing please selects the certain strength of wood or similar wood material packing can be fixed packing.

b) Security considerations of the machine packaging:

- ① When packing, the internal need to certain strength of wood or similar materials to support machine won't be overturned when in the packaging box.
- ② It's necessary to show the warning signs in the outside of packaging box to show the packing cannot be inverted.
- ③ In the Box near the surface of the machine where the flexible material required to isolating the internal support frame to avoid scratching the machine.
- ④ There shall be no weight or iron nails drop inside of the package box when packing the items.

c) There is not allow to see any objects in the tablet of weighing when packing so that can prevent the damage of weighing sensor.

### 2、 The transportation of the machine

Packaging machine with the maximum weight within the 200 kg, can transport the machine by the tools which can load the goods in 200kg or above.

### 3、 The transport condition and notices of the machine:

The machine must remain stable during the transit, can not be overturned, tilted and impacted.

### 4、 The storage conditions of the machine

The machine can be stored at room temperature environment. That's necessary to preventing dust, damp and corrosion.

### Chapter 3: The introduction and specification of check weigher

#### 3.1 The introduction of check weigher

Check weigher adopts advanced technology, high-speed MCU control, used to detect a single product weight and setting goals are consistent, and by sorting device automatically weed out substandard products. This product built-in world advanced digital weighing unit which can realize the measurement of high-speed, accurate and stable. Widely used in automatic production integration of the packaging industry.

#### Structure of product

This machine is mainly composed of microcomputer system, display system, conveyor system, weighing system and eliminating system structure

#### Microcomputer system

By single chip microcomputer circuit for real time detection and monitoring, can measure accurately and rapidly, realize the separation of substandard products. Microcomputer system can store multiple parameters; users can according to their own products to invoke the stored parameters, which brought great convenience to them. Can be achieved the different range of detection through modify the parameter. Meanwhile the microcontroller can also store the record of unqualified products.

#### Display system

Provide the high definition touch screen as the simple interface to the user.

#### Conveying system

The conveying system was composed of brushless motor and conveyor belt. Brushless motor driver module provides the motor with high torque, high precision, wide speed range of the drive, has realized the uniform motion of the item, the weighing unit can check the item weight more accurately.

## **High-speed Check weigher**

---

### **Weighing system**

The weighing system was composed by the main weighing unit and vibration weighing units. Put in the vibration weighing unit to prevent the vibration caused by the outside world for high-speed check weigher. Weighing and vibration unit adopts the high precision, high speed high sensitive weighing sensor, the goods will force the information counter rotating into electrical signals by weighing module through the sensor, after communicate with the single chip microcomputer then displayed on the touch screen.

### **Eliminate system**

The main powered by air, detect to weed out the unqualified products by single chip microcomputer.

## High-speed Check weigher

### 3.2.The main technical parameters of the check weigher:

<b>Model</b>	MD-W100
<b>Division Value</b>	0.1g or 1g
<b>Weighing Scale</b>	10g-1Kg
<b>Sorting institution</b>	Pusher for power
<b>Product default mode (Kind)</b>	10
<b>Maximum detection speed</b>	120 Bags/Min
<b>Maximum precision</b>	$\pm 1g$
<b>Working temperature range</b>	-5~40°C
<b>Working humidity range</b>	35~85%
<b>Working voltage</b>	AC220V
<b>Power frequency</b>	50 / 60Hz
<b>Rated power</b>	500W
<b>Net weight</b>	130KG
<b>Gross weight (After packaged)</b>	200KG

## Chapter 4 The external structure of machine

### As see the Chart 4-1 Main components

- 1、 Touch screen
- 2、 The power switch



## High-speed Check weigher

- 3、Photoelectric detection
- 4、Digital high speed sensor
- 5、Eliminating device
- 6、The air pressure valve
- 7、External dimensions 1455 (L) ×625.45 (W) ×1348 (H)

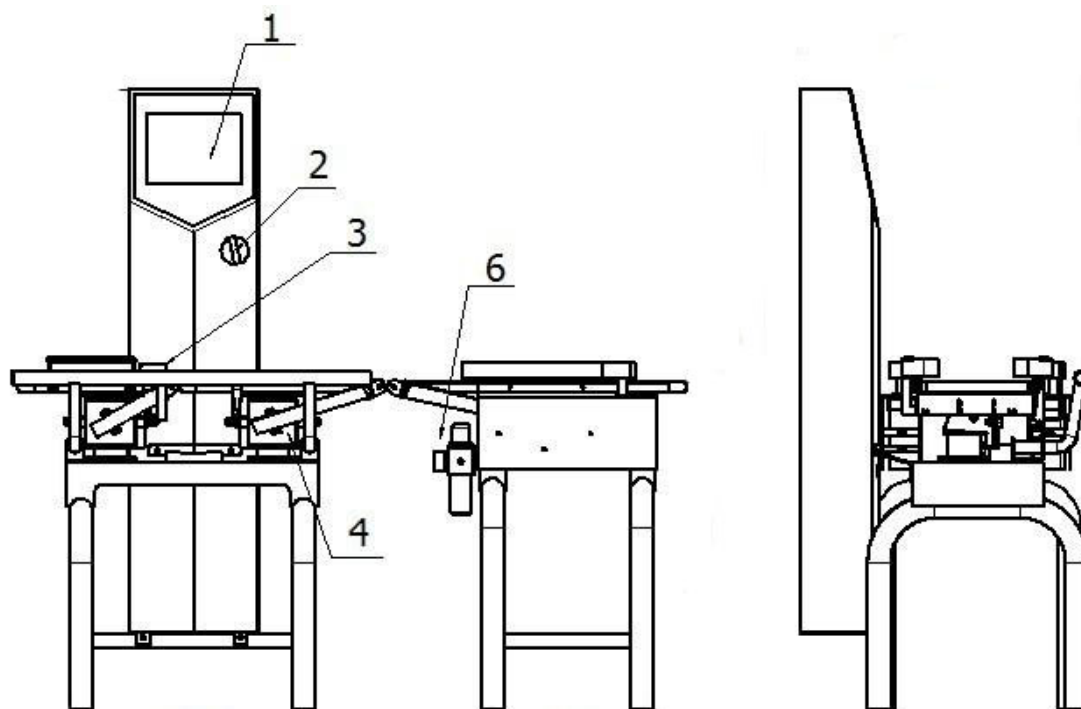

Chart 4-1

## Chapter 5 Operating instructions

5.1 Start up the main screen (see the chart 5-1)

## High-speed Check weigher



Chart 5-1

a) Reset

After entering separating interface, sensor began to constantly collecting, so in the absence of items in the observable zero is accurate, such as zero drift, press the "reset". Valid for this operation is limited to drift in 300 g; or please enter the "parameter setting" interface initialization calibration.

b) Heavy start/stop switch

Heavy start/stop switch is located in the upper right corner  
"Parameter setting" can enter only in stop state.

a) 0#-9#

It meant the 10 formula shortcut buttons. Click on the different formula can modify the corresponding formula changes.

## High-speed Check weigher

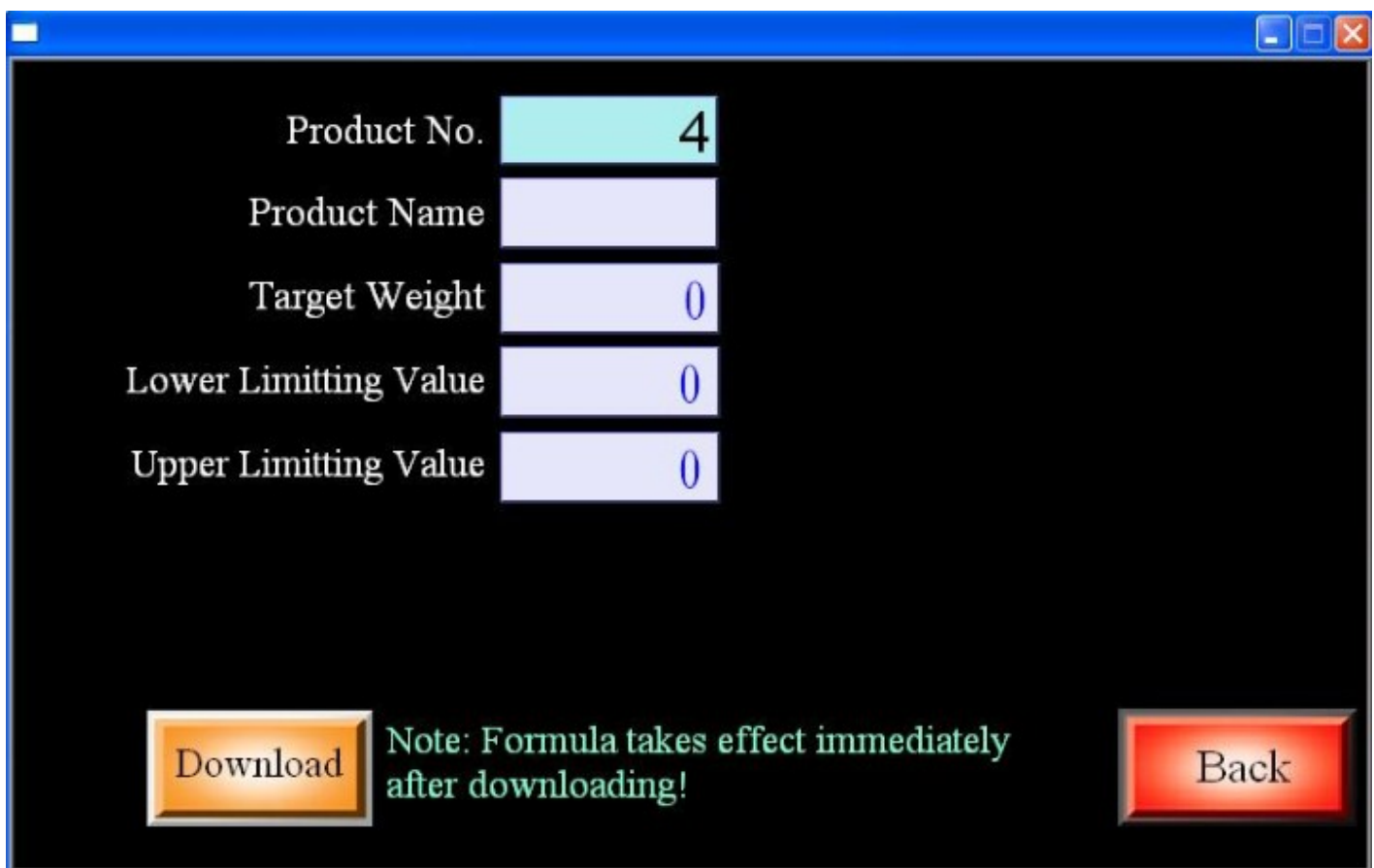

The screenshot shows a software window with a blue title bar and standard window controls (minimize, maximize, close) in the top right corner. The main area has a black background with white text. There are five input fields arranged vertically, each with a label to its left. The first field, labeled 'Product No.', contains the number '4'. The other four fields, labeled 'Product Name', 'Target Weight', 'Lower Limiting Value', and 'Upper Limiting Value', all contain the number '0'. At the bottom of the window, there is a yellow 'Download' button on the left, a red 'Back' button on the right, and a green note in the center that reads: 'Note: Formula takes effect immediately after downloading!'.

Product No.	4
Product Name	
Target Weight	0
Lower Limiting Value	0
Upper Limiting Value	0

**Download** **Note: Formula takes effect immediately after downloading!** **Back**

Please note that after revised formula must download so that can take effect immediately without downtime!

# High-speed Check weigher

## 5.2 Statistical reports

	0#	1#	2#	3#	4#
Product ID	0#				
Product Name	XIAOM000				
Total	6	0	0	0	0
OK	2	0	0	0	0
NG	2	0	0	0	0
Cumulative Weight	2	0	0	0	0
OK Cumulative Weight	0	0	0	0	0
NG Cumulative Weight	0	0	0	0	0

The statistics can refer to the 10 set of formula statistics.

Customers can free to remove each set of formula statistical data, can also according to the "all clear" button to remove all of your data, note that once the data cleared, will not be able to recover.

Customers can also be equipped with SD card to check all the weight values of check-weighing and the weight values for unqualified products.

## High-speed Check weigher

---

### 5.3 Main interface of parameter Settings

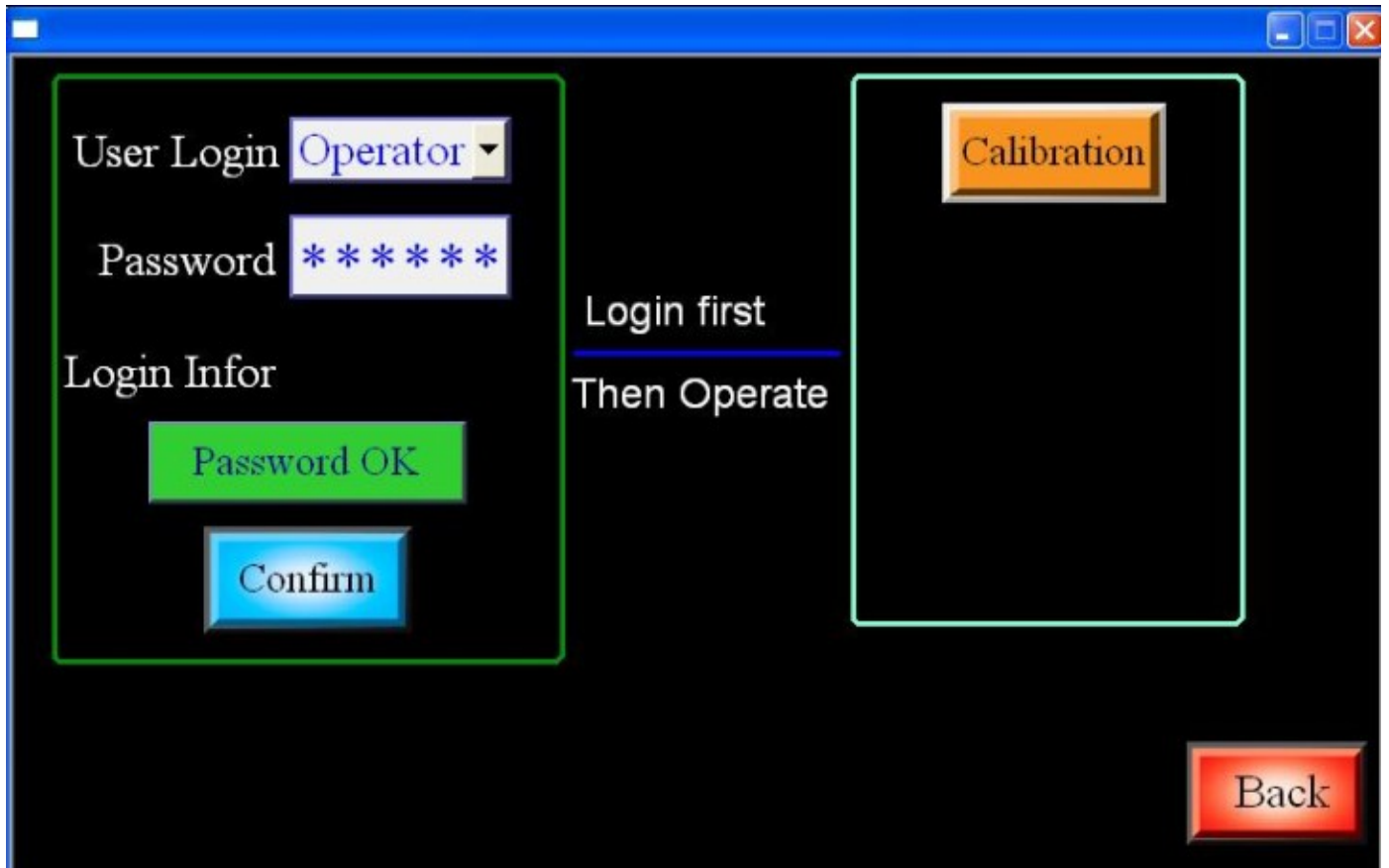

## High-speed Check weigher

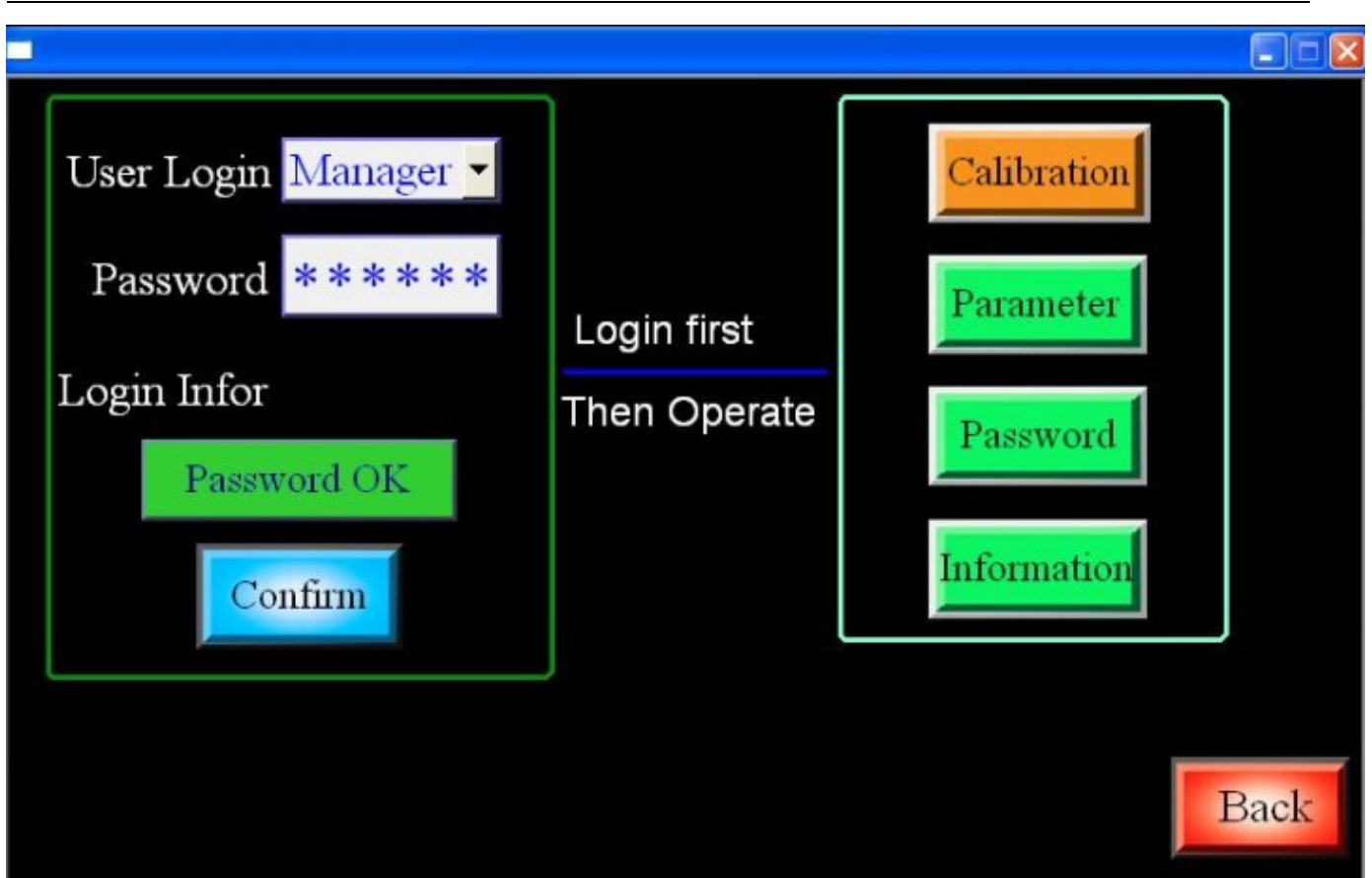
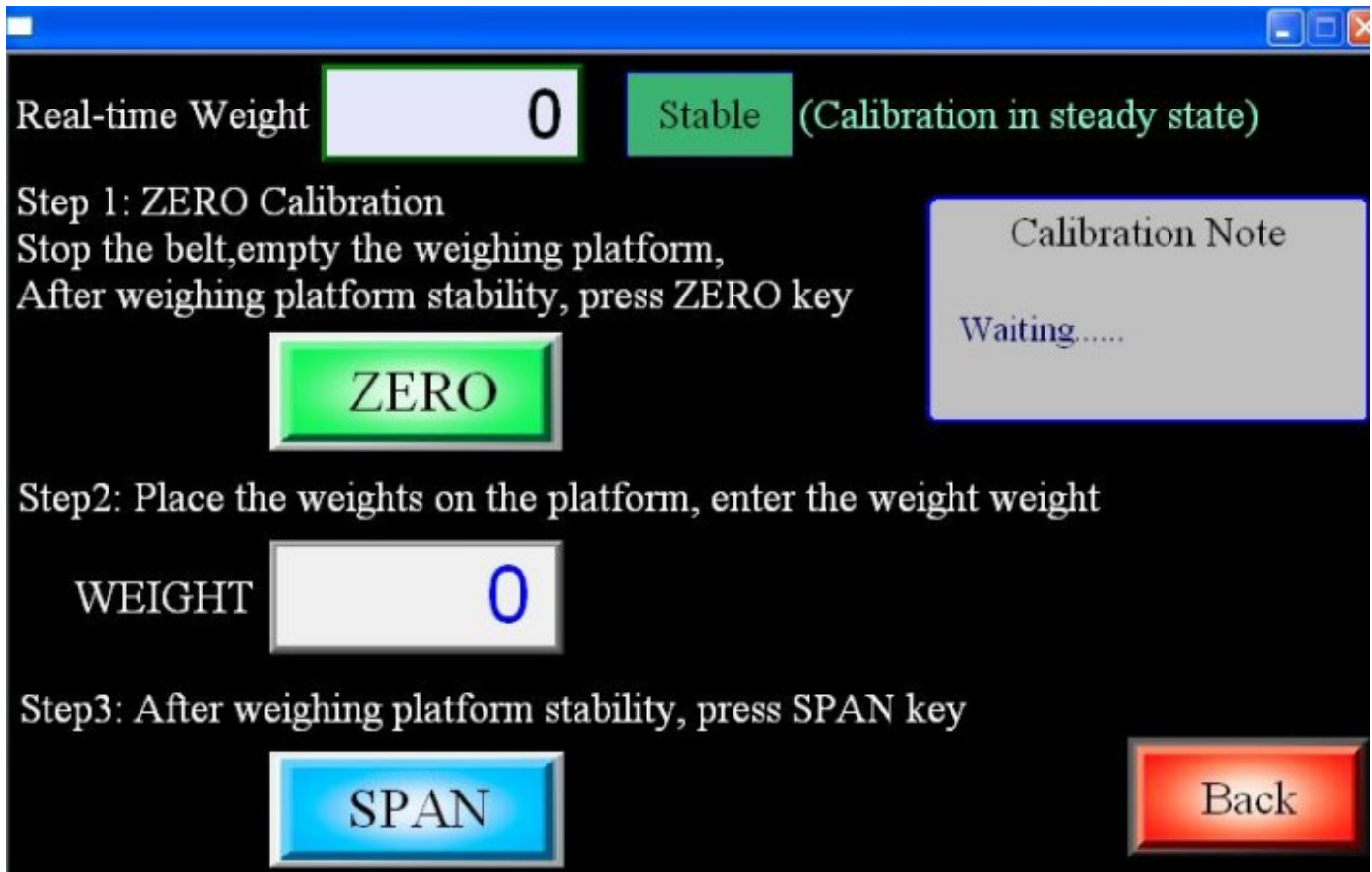

Chart 5-4-2

As see the below Chart 5-4-2,Parameter Settings include "calibration" and "parameter setting" three "change password", all need to operate after login. Operator only "calibration" item operation after login, the administrator can operate on the above three after login

## High-speed Check weigher

### 5.4 Calibration interface



## High-speed Check weigher

### 5.5 Parameter Settings interface

Output delay time	0.00
Output keep time	0.00
Alarm delay time	0.00
Filter factor	0
Correction factor	0
Dynamic range	0
Set the belt speed(Write)	0.00
The current belt speed setpoint	0.00

Back

Please note: The parameters has been set up when ex-factory generally, so the customers are required that not to modify freely, before modify do remember write down the original value firstly.



### 5.6 Change the password

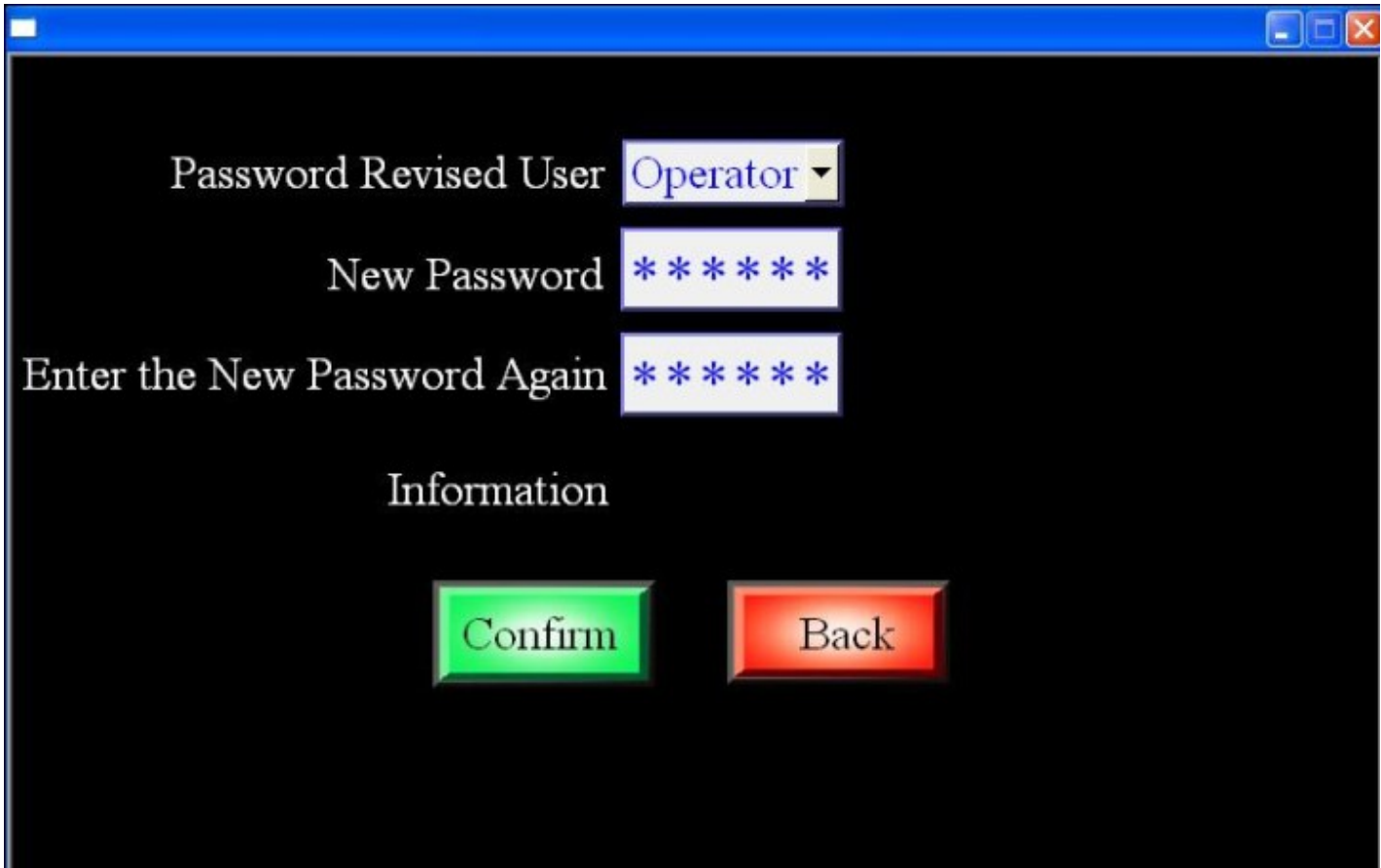

Password Revised User

New Password

Enter the New Password Again

Information

Administrators can modify the operator password and own password, after modification it should be kept in mind deeply, if forgets, can only be sent back to the factory for refresh the program.

## Chapter 6: Maintenance

### 1、 The general principles of the machine maintenance:

- a) Keeping the exterior surfaces shall have no dirt, oil, moisture or other corrosive stain.  
Cleaning once a week normally.
- b) Conveyor belt cannot be stayed the foreign matter.
- c) Conveyor belt must keep clean and cleaning once a week normally.

2、 Conveyor belt can be removed after tainted with a cleaning solution to clean. And installed conveyor frame after drying.

3、 Stains on the surface of the machine can use detergent to wash.

## High-speed Check weigher

---

4、 The whole machine cannot clean by thinner or similar liquids in case damage the machine.

### 5、 **The security check after the maintenance:**

Machine maintenance please check around the cable, power cable, signal lines, whether foot screws around the lock, whether the machine is level, whether transport rack installation in place, whether the belt and pulley is aligned, conveyor belt whether is corrected, in the process of running, whether the conveyor belt to walk .

## Chapter 7 Repair

### 1、 **Common faults and troubleshooting for machine.**

#### a) Conveyor belt to walk:

Adjust screw conveyor belt transmission balance, try to make the conveyor walk the middle of the conveyor frame.

#### b) The whole machine without electricity, does not work:

Check whether the switch is in the open position, testing the internal leakage switch is protective.

#### c) Operation screen does not display.

Check the wire behind the screen is loose or not, testing the internal switch power indicator light whether is bright, if not meant the switching power supply has been damaged.

#### d) Conveyor belt not work:

Check the belt whether has the main object stuck, whether the belt has loosed, slipped, if there's any loose for motor line.

#### e) Does not work to weed out the unqualified products:

Check the internal eliminate part of the line whether is loose, slip, the cylinder whether can work as normal, adjust the magnitude of the air valve.

#### f) Show the weight of the floating:

Check the tablet of weighing whether touching other tablets, check whether has the interference sources around, stay away from the wind source. Check whether the rolling

## High-speed Check weigher

---

bearing is badly worn.

### 2、 Safety precaution of the machinery maintenance:

- a) Make sure to pull the plug out when the machine maintenance.
- b) Separate the power cord and signal lines please do not connect the wrong way.
- c) Do not use the heavy objects to knock the outer shell of the machine.
- d) Do not put the maintenance tools with dirty oil on the conveyor belt.
- e) The weighing sensor cannot weighed much, should pay more attention when maintenance.

### 3、 The security check after the maintenance:

- a) Check all the ground wires, power cords, signal wires whether has connected well.
- b) Start the conveyor belt and adjust it in the middle of the conveyor frame to operate, cannot let the conveyor walk one side.
- c) Belt and pulley must be aligned, make sure has the good connecting when transmit, not allow to have a bad interference of the noise.
- d) The transport rack must be put in place and locked with card buckle.
- e) Anchor bolt must be locked after adjust the balance.